

# Product Engineering Guide

## Commander v10 PhilipsLM v10

---

### Introduction

The PhilipsLM Commander, called Commander within this document, is a powerful IP based controller and provides a configurable link between other systems on an Ethernet network and the Philips Light Master System.

The LightMaster system is a modular lighting system where LightMaster Area Controllers are networked together allowing access to Lighting Control Modules, which host the output lighting ports and the input sensors. The lighting ports provide variable lighting levels for luminaires.

Commander has an Ethernet port supporting a range of IP based protocols in addition to the Philips Light Master Protocol. This allows Commander to access values on the Philips System and Ethernet networks, and allows other devices on the Ethernet networks to access values within Commander using a wide range of communication protocols. Commander can also act as a bridge providing communication between these networks.

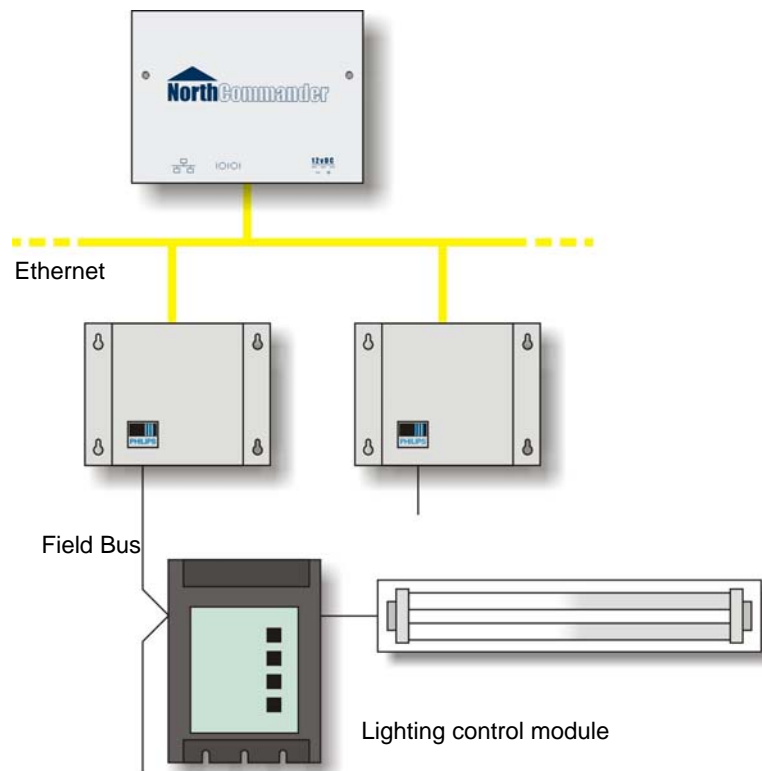

### Features

Commander contains a range of software modules that provide Alarm handling, Networking services, and Data Acquisition & Control.

#### Supported Range

- Philips ECS LightMaster 100 system

#### Notes

The LightMaster system does not report alarms to commander. If alarms are needed then an AlarmGen device will be required.

The LightMaster system does not provide logging facilities to Commander. If logging of values is needed then a Data Manager will be required.

---

## **Networking**

Commander contains several modules that provide network-based services:

- IPBus Interface – allows Commander to access objects within other IPBus (XOM/IP) compatible devices on the IP network, such as North ObSys and other Commanders. It also allows other IPBus compatible devices to access objects within Commander
- User Database – collects values from the attached systems. It acts as a database of summary information that is aimed at users. Users can view and set the information in the database in several ways: from the Web Server; from the BACnet controller; and from attached compatible devices
- Web Server – automatically generates HTML pages using information collected by the user database and alarm event history. Access to specific pages or values can be controlled using the authentication server
- BACnet Application Specific Controller – supports the ASHRAE BACnet (Building Automation and Control Networks) standard. Information from the user database is automatically presented as BACnet objects
- Authentication Server – identifies tokens and access levels for 250 users. Provides authentication for the Web Server, attached devices, and other devices on the IP network

Once connected to the Ethernet network, Commander can be configured via IPBus using object engineering software such as North ObSys.

## **Alarm Handling**

Commander contains several intelligent alarm handling modules, including:

- Alarm event distribution and routing – routes alarm events to destinations within Commander, the attached system, and Ethernet network depending on configurable criteria
- Alarm event history – stores the last 100 alarm events received
- SNMP Trap notification – reports alarm conditions to a management station trap handler
- E-mail notification of alarm events – sends alarm events as e-mail messages
- Monitoring of values and alarm event generation – the user database monitors the values collected and generates alarm events if required

Modules within Commander, the Philips System, and devices on the Ethernet network can send alarms events to the Alarm Router for distribution. The Alarm Route module sends alarms to other alarm objects within Commander, on the Philips System, and on the IP network.

## **Control**

- Programmable Control – OBVEngine allows the engineer to develop processes to control objects within Commander, the attached system, and on the Ethernet network
- Time Control – uses Commander's date and time to provide on-off time control to other devices. The Calendar is used to specify day-types for the following year, and each of the timers then has a set of usable profiles for each day-type.
- Data Logging – allows Commander to log up to 32 different points and stores the data for use by other object-based software such as the ObSys Data Manager or LogView

# Engineering

## Step 1 – Install the Commander

Refer to the [Commander Installation Guide](#) for details on how to mount the Commander securely to a wall or within a cabinet.

## Step 2 – Connect Commander to the Philips System

The Commander should be connected to the same network as the Philips LightMaster system, or be routed such that it has access to the LightMaster System. Commander uses UDP on ports 51783 and 51784 to communicate with LightMaster.

## Step 3 – Apply Power and Enable the Battery Back-up

Commander requires a regulated 12VDC ( $\pm 10\%$ ) power supply and draws up to 500mA maximum. Connect power as shown in the diagram below.

Commander contains a Lithium-ion rechargeable battery. Do not short-circuit the battery, or place on a metal surface where the battery terminals could be shorted. The top surface of the battery is live. During shipment the battery is disconnected and should be connected before engineering Commander. To connect the battery place a jumper over the lower two pins marked BATT (see diagram below).

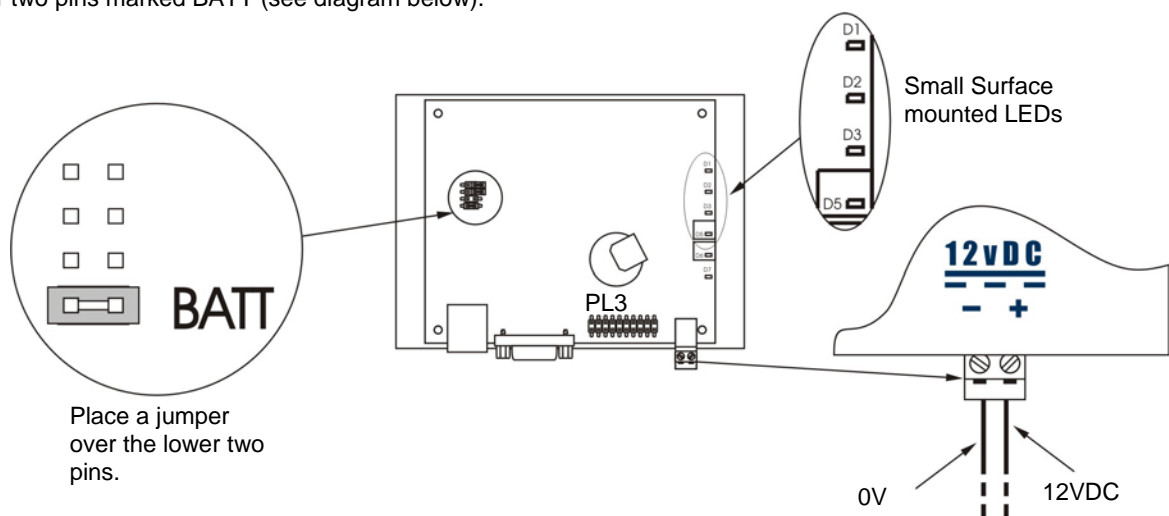

If the battery jumper is fitted and the board is left without power, then the battery will typically support the Setup module storage and real time clock for 10 months.

## Step 4 – Configure the Commander Network Settings

Commander is supplied configured with the default IP address 192.168.2.200 and a network mask of 255.255.255.0.

Configure Commander's network settings to avoid a duplicate address and to match the local network class. Refer to the [Configuring Network Settings](#) section below for more details.

## Step 5 – Connect Commander to the Ethernet Network

Attach the Commander to a 10Base-T compatible Ethernet network switch or hub using CAT-5 cable with RJ45 connectors.

The red LED marked D5 should light to indicate the presence of a physical Ethernet connection.

## Step 6 – Configure Engineering Software

Configure the IPBus module within your object engineering software, such as ObView. The IP address of Commander should be added to the alias table. Refer to the [OSM v20 IPBus v20 Engineering Guide](#) for more details.

## Step 7 – Set the Date and Time

Set the current date and time in the Commander General Setup module. The daylight-saving start and end periods may also be configured. Reset the Commander to enter the correct time and date in the last restart field.

## Step 8 – Configure the Driver Module

The Areas IP address, number and alarm destination are configured using objects. Use object engineering software to view and modify the module objects within the Commander.

---

### **Step 9 – Configure the Commander Control Modules**

ObVerse processes can be configured and downloaded to the OBVEngine module. Use the OBVEditor to author, download and monitor these processes.

If required, Commander's calendar and clock can be used to provide on-off time control to devices attached via the Ethernet or Philips networks. The Calendar is used to specify day-types for the following year, and each of the timers then has a set of profiles to be used.

If data logging is required, configure the number of logging channels required from the LogMax module and then configure each logging channel.

For more information, refer to the [\*Introduction to Commander Control\*](#).

### **Step 10 – Configure the Commander Alarm Modules**

Alarms generated by the various modules within Commander, or sent to Commander from another device, may be routed using the Alarm Route module. If required, configure the Alarm Route destinations.

If the Alarm History module is required, route alarms to this using the Route Object 'HD.ALARM'

If an e-mail server is available on the Ethernet network, configure the Alarm Email module with the IP address of the destination server, and destination e-mail accounts. Alarms should then be routed to the Alarm Email device.

If a network management SNMP trap handler is available on the Ethernet network, configure the SNMP Trap module with details of a destination IP address and MIB name.

For more information, refer to the [\*Introduction to Commander Alarms\*](#).

### **Step 11 – Configure the Commander Networking Modules**

If required, configure the pages and objects within the User Data module. The Web Server and BACnet modules can then present this data. The User Data module can also monitor the objects configured and generate alarm events.

If a Web Server is required, enable this from the Web Server module. Web pages are automatically generated from data within the User Data and Alarm History modules. User authentication may also be provided from the User Token module.

If the BACnet protocol is used on the IP network, enable the Commander's BACnet device by configuring the BACnet Device Instance. This number allows the User Database to appear as BACnet objects on the IP network.

The User Token module can provide authentication for the Web Server and compatible devices attached to the Ethernet or Philips networks. If required, logon and configure users within the User Token Setup module.

For more information, refer to the [\*Introduction to Commander Networking\*](#).

---

## Configuring Network Settings

Commander is supplied pre-configured with the IP address 192.168.2.200. This section describes how the IP settings may be configured manually or assigned from a DHCP server, using either the Terminal Port or Telnet module.

The Terminal Port or Telnet module can also provide useful fault finding information.

### Connecting to the Telnet Module

Connect directly to Commander from your PC using a CAT5 cross-over cable. The red LED D5 will light to indicate the cable is connected correctly.

Configure your PC's network connection with an IP address of 192.168.2.2 and a subnet mask of 255.255.255.0.

Launch your telnet client software with the Commander address, for example at the Windows command prompt type:  
TELNET 192.168.2.200↵

The server uses the default Telnet port of 23 and all commands should be followed by a carriage-return and line-feed.

Once connected, Commander will then prompt for the user logon. Enter the default user logon of (blank):

User: ↵

Once logged-on to the Telnet session, Commander will request which service is required. For object based communications with Commander enter 'qr':

Service:qr↵

Commander is now ready to have values read from and written to it. Enter commands at the Q prompt:

Q:

Telnet can be used to read from any object within Commander, from other IPBus devices, and from the connected system. It can also be used to write a value to these objects.

For more information, refer to the [Introduction to Commander Networking](#).

### Connecting to the Terminal Port

If the IP address is unknown, Telnet cannot be used. Commander has a port that can be used for local configuration and test purposes. A special converter, order code MISC/CMDRCONV, is needed to connect terminal software to this port.

Connect the converter to Commander port PL3 with 'edge side' label towards the bottom edge of the board. Connect your PC using a standard serial modem cable.

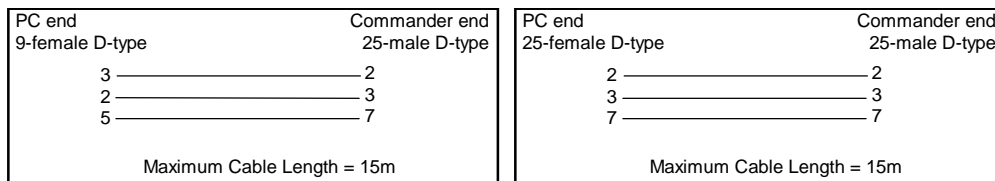

Once connected, use terminal software (such as HyperTerminal) to check the operation and read and write objects within Commander. The terminal software should be set to **19200 baud, 8 bits, no parity, and no flow control**.

The green LED D2 will light when receiving data, and D1 will light when Commander is transmitting data on port PL3.

The Terminal Port can be used to read from any object within Commander, from other IPBus devices, and from the connected system. It can also be used to write a value to these objects.

### Accessing Objects

Once connected using either Telnet or the Terminal Port, objects may be read or written as follows:

#### Reading Objects

Type the object reference and press carriage-return (↵) to read the object's value (object references are case sensitive). For example, to read the date and time from Commander, type:

C.DT↵

Commander responds with the date and time:

13/09/05|12:30:08

#### Writing Objects

Type the object reference, the equal sign, the value, and then carriage-return, to write the object's value. For example, to write the date and time to Commander, type:

C.DT=13/09/05|12:22:00↵

Commander responds with 'Ok' when the value has been written.

---

## Configuring the IP Address

Each IP device on the Ethernet network has a unique address that may be configured in one of the following ways:

- Fixed address. If a static IP address is required, the IP address and related network settings may be configured manually
- Automatically assigned using a DHCP server. When powered up, Commander asks the DHCP server for an IP address. The server supplies a unique IP address, as well as the other settings related to the network configuration.

### Fixed IP Address

Commander is supplied pre-configured with a fixed IP address. This address should be unique on the Ethernet network and may require changing. Contact your network administrator for an available IP address, network mask and gateway address.

Connected to the Telnet or Terminal Port, use the following commands to configure the IP network settings:

```
C.IA=<Commander IP address> ... to set the Commander's IP Address (default: 192.168.2.200)
C.IM=<IP Network Mask> ... to set the IP network mask (default: 255.255.255.0)
C.IG=<Gateway IP address> ... to set the Gateway's IP Address (default: 0.0.0.0)
C.Irst=1 ... to reset the Commander
```

For example, if your IP network has addresses 192.168.2.x, and the Commander's address is to be 192.168.2.10, and the gateway's address is 192.168.2.254, then type the commands:

```
C.IA=192.168.2.10␣
C.IM=255.255.255.0␣
C.IG=192.168.2.254␣
C.Irst=1␣
```

### DHCP Assigned IP Address

Commander can be configured to obtain its IP address from a DHCP server. When powered on, Commander will request IP address information from the DHCP server.

It is recommended that Commander should keep the same IP address. Contact your network administrator to configure a DHCP reservation.

If you want to use a DHCP assigned address, set the IP address to 0.0.0.0 and reset Commander.

Type:

```
C.IA=0.0.0.0␣
C.Irst=1␣
```

To check the current IP address, type:

```
C.CIA␣
```

---

## Ethernet Engineering Reference

### Objects

Once the IP settings are configured, the Commander's main object (which contains other objects) is created on the IPBus network. Use object software, such as ObView, to access these objects.

<b>Object</b>	<b>Label</b>	<b>R/W</b>	<b>Type</b>
o <sup>[1]</sup>	Commander Main Object	-	<a href="#">[Commander v10\PhilipsLM v10]</a>

### Notes

[1] The object, o, is the alias configured within the IPBus module accessing the IP network.

## Notes

### Order Codes

CMDR/PHILIPSLM	Commander with PhilipsLM interface.
MISC/DINKIT	DIN-rail mounting kit for Commander.
MISC/CMDRCONV	Commander terminal port converter.