

Product Engineering Guide

Compass v22 LonSLTA v11 RS232

Introduction

The Compass v22 LonSLTA v11 Compass Point, called LonSLTA within this document, links a LON network, via Echelon Corporation's SLTA device, to the Compass Network. Network variables within each of the LON products on the LON network can be accessed from Compass, along with network variable configuration and domain tables.

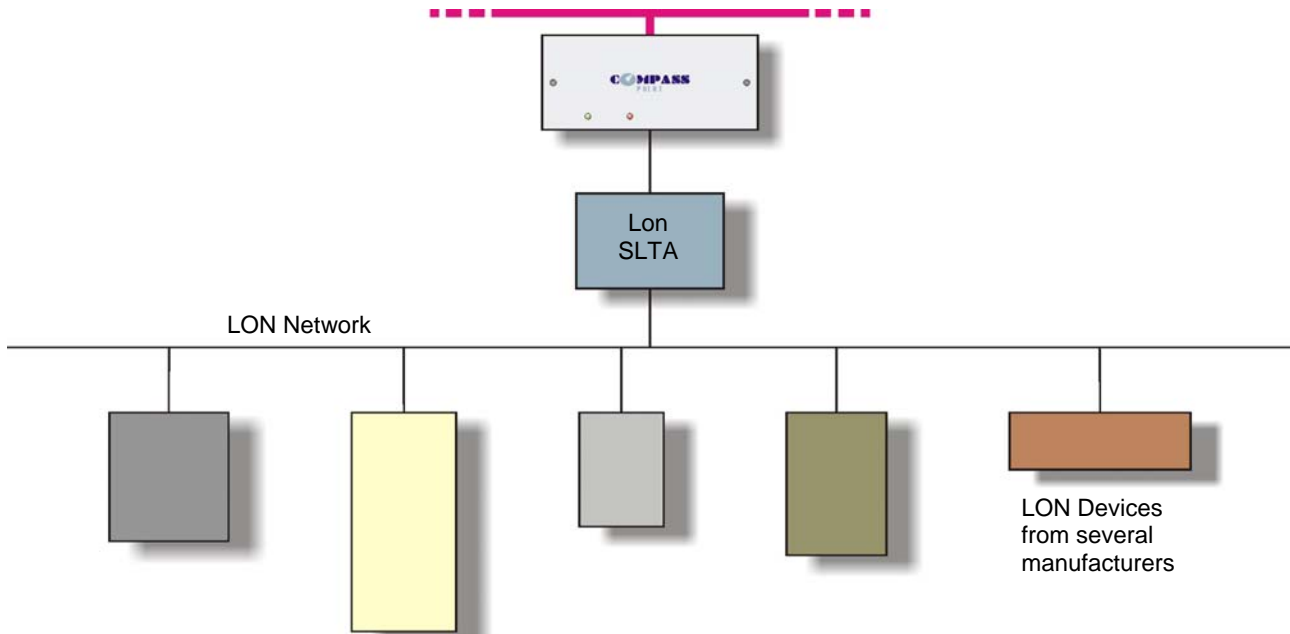

Each device on the LON network, including the SLTA, must be assigned a domain number. Devices can communicate with other devices within the same domain as them. One aspect of engineering is to determine which domain the SLTA will reside.

LON Addressing

Within a domain, each device has a unique subnet/node number. Subnet numbers are in the range 1...255, and node numbers are in the range 1...127. Before requesting values from a device, its subnet and node number must be determined. The SLTA, being a device on the LON network, must also have a subnet/node number assigned.

There are two ways of assigning a domain, subnet and node number to the SLTA. The first is to use LON engineering software and assign the numbers from the LON network. The second is to have the Compass Point assign them from the RS232 link.

Neuron ID Addressing

It is possible to use a LON Neuron Id to access a device, rather than its domain, subnet, and node. Although this is not recommended for normal operation, it is useful when engineering. A Default Neuron ID is written to the Compass Point (or loaded by pressing the Service Request pin of a device), and then the device with the ID is accessed using the object D. See 'Default Neuron ID' section below.

Engineering

Step 1 – Mount the Compass Point

Refer to the 'Mounting' section within the '[Compass Point RS232 Installation Guide](#)' document for details on how to mount the Compass Point securely to a wall or within a cabinet.

Step 2 – Connect SLTA to LON Network

Refer to SLTA documentation on how to connect the SLTA to the LON network

Step 3 – Configure SLTA

The SLTA has a set of switches that define the protocol settings for the RS232 port. Refer to the section 'SLTA Switches' below for more information.

If necessary, use your LON engineering software to assign a domain, subnet, and node number to the SLTA.

Step 4 – Connect Compass Point to SLTA

Using cable, connect the 9-way female D-type connector on the LonSLTA to the RS232 port of the Compass Point. Refer to the section 'Cable' below for details of the cable.

Step 5 – Apply Power to the Compass Point and SLTA

Refer to the 'Power' section within the '[Compass Point RS232 Installation Guide](#)' document. Once power is applied, the green LED should be lit continuously to show that the Compass Point is working correctly on the Compass Network. Apply power to the Lon SLTA.

Step 6 – Configure the LonSLTA driver within Compass Point

The Compass Point driver can download the SLTA's domain number, subnet number, and node number to the SLTA if necessary. This is configured using objects. Use object engineering software to view and modify the object within the Compass Point.

Step 7 – Access Objects within the LON System

Values from a device on the LON network are made available as objects on the Compass Network. Any object software that is connected to the Compass Network can access these objects.

The red LED near the RS232 port of the Compass pulses when a valid message is transmitted or received by the Compass Point.

Step 8 – Configure the Transfers within the Compass Point

Compass Point transfers are also configured using objects. Refer to the '[Introduction to Compass Transfers](#)' document for more details.

Step 9 – Configure the Alarm Handling within the Compass Point

Compass Point alarm handling is also configured using objects. Refer to the '[Introduction to Compass Alarms](#)' document for more details.

Engineering Reference

Cable Specification

The cable between the Compass Point and the 9-way female D-type connector on the LonSLTA is as follows:

Compass end 25-male D-type		LonSLTA end 9-male D-type
2	—————	2
3	—————	3
7	—————	5
8	—————	4

Maximum Cable Lengths = 15m

SLTA Switches

The SLTA has switches that select how the SLTA communicates on its RS232 port. Below are tables showing the switch setting to use on different SLTA devices.

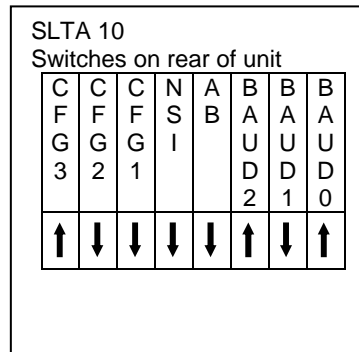
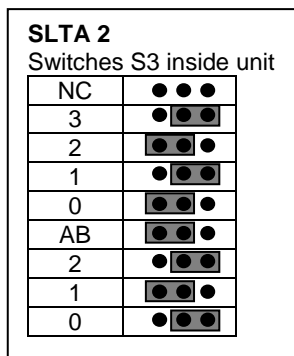

NOTE: These diagrams both show the settings for 38400 baud.

Default Neuron ID

Normally devices are addressed using an object reference SxNy, where x is the subnet number within the device, and y is the node number of the device.

If the Default Neuron ID object within the Compass Point is set to a valid Neuron ID, the device with that ID can be addressed using the object reference D.

The Default Neuron ID can either be set manually using object engineering software, or can be set by pressing the Service Pin on a particular device. If the Compass Point receives the service message, it will set the Default Neuron ID to the ID within the service message. Once the Default Neuron ID has been set, then it must be blanked again before the Point will listen for the next service message.

Objects

When the Compass Point is powered-up the following objects are created on the Compass Network, use object software to access these objects.

Object	Label	R/W	Type
Dn ^[1]	LON System	-	[Lon\Network] ^[2]
Pp ^[3]	LON Compass Point	-	[Compass v22\ LonSLTA v11]

Notes

[1] The Device Number, n, is a number in the range 0...63.

[2] This object has a variable content and as such requires scanning.

[3] If the Compass Point has its device number configured the Point address, p, is a number in the range 1...63. If no device number is set the Point address, p, is the Compass Point serial number in the range 1000000...9999999

Notes

Revision History

Version	Build Date	Details
1.1	04/09/04	Fix: Variable numbers greater than 256 where not handled correctly.
1.1	03/03/05	Fix: Document change to correct subnet/node number range. Mod: Add support for new SNVT types (Quad's and double-precision floating points)