

Installation Guide

Zip Display Module 7202

Introduction

Zip is a networked data acquisition and control system. A Zip system consists of a controller, called a ZipMaster, and up to 16 acquisition, control and display modules. Each module has network communications capability to allow it to be positioned near the plant, some distance from the ZipMaster. This document will cover the stages needed for correctly installing the Zip Display Module.

The Zip Module, like all electronic devices, should be handled carefully to prevent damage.

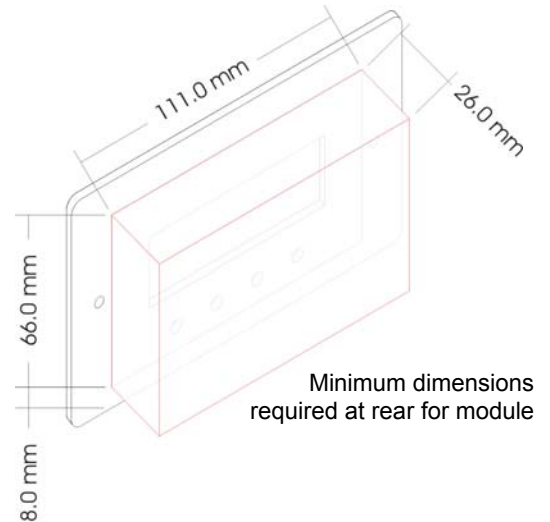
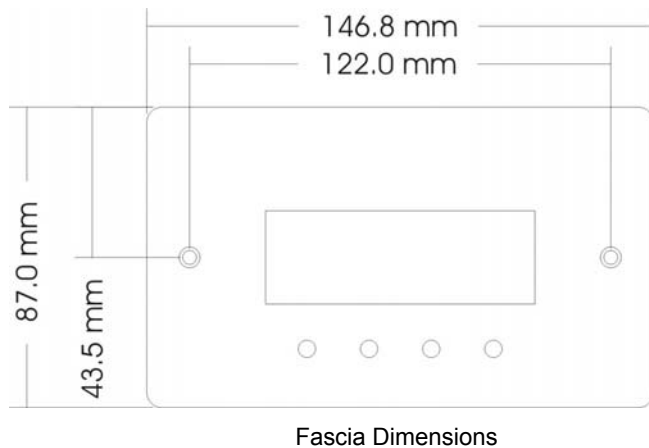

Technical Data

Power rating	12VDC \pm 5% 200mA regulated
Thermistor Input	10K3 temperature thermistor, 10K Ω at 25°C
Maximum Zip Modules	16 Modules per network
Mounting	2-gang electrical mounting box (pattress, dry-lining box, etc.) The display may be wall, panel or surface mounted.

Check Before Installation



- IMPORTANT:** Each Zip Display Module requires 12VDC (\pm 5%) and can use up to 200mA maximum. Connecting the power incorrectly or connecting an inappropriate power supply will damage the board or seriously affect its reliability.
- Check that the location where the Zip Module is to be installed is free from electrical noise and vibration, and is a relatively dry environment. Excessive noise, such as that generated by a dimmer switch, can have a detrimental effect on Zip and power supplies.
We recommend that the Zip Display be installed within the metal electrical mounting box supplied.
- Use appropriate cable for creating the Zip network. Recommended network cables include Belden 8761, Alpha 2401C, BICC H8082 or Brand Rex BE-56761. Avoid running network cables parallel to power cables, especially if they carry large currents, or are switched on/off frequently.
The maximum single cable length between Zip modules is 1000m.

Installing the Zip Display

Step 1 – Install Pattress

Install the supplied 2-gang electrical mounting box (pattress) in a suitable wall, allowing for the routing of the Zip network and power cables.

An alternative surface mount or panel mount pattress may be used. Refer to the diagram on the previous page for size requirements.

Step 2 – Configure Module Address Switches

Configure the Zip Module on the network with a unique address in the range 0 to 16. The Module address is set using the 4-way DIP switch as follows:

Module Address	Switch Position			
	1	2	3	4
0	Off	Off	Off	Off
1	On	Off	Off	Off
2	Off	On	Off	Off
3	On	On	Off	Off
4	Off	Off	On	Off
5	On	Off	On	Off
6	Off	On	On	Off
7	On	On	On	Off

Module Address	Switch Position			
	1	2	3	4
8	Off	Off	Off	On
9	On	Off	Off	On
10	Off	On	Off	On
11	On	On	Off	On
12	Off	Off	On	On
13	On	Off	On	On
14	Off	On	On	On
15	On	On	On	On

Example



With the Address Switch set with 1=on, 2=off, 3=on, 4=off, the modules address will be 5.

Step 3 – Connect the Zip Network

The Zip Display is connected together with other Zip NetCards on a 2-wire RS485 bus. Each Zip M7002 and NC12A NetCard has two network connections. Starting at one end, connect the cards together: connect the + and - terminals to the next cards + and - terminals to form a bus.

The last Zip NetCard may require a terminating resistor of 125ohms, which connects to the spare RS485 terminals.

Step 4 – Connect to the ZipMaster

If using the ZipMaster on the Compass platform, simply connect the RS485 Zip network to the device port.

If using the ZipMaster on the Commander or ObSys platforms, a Zip NC12B NetCard (RS232) is required. Connect the ZipMaster to the NetCard using an RS232 cable. Refer to the North Helper for documentation on the ZipMaster cable requirements.

RS232 cables to connect the ZipMaster and NC12B are also available from North, order code [platform]\CABLE\ZIP.

Step 5 – Connect Thermistor (Optional)

Connect the 10K3 thermistor to the Zip Module. Refer to the [Zip Module 7202A Engineering Guide](#) for more information.

Step 6 – Connect Power

Each Zip Display requires 12VDC ($\pm 5\%$) and draws up to 200mA maximum. The power connector is polarity dependant and must be wired as marked on the board. Connect the power supply to the Zip Display but do not power it on.

Step 7 – Fitting the Zip Display

Fit the Zip Display to the back-box (pattress) that you have fitted in your wall. This is done with the two supplied M3.5 x 25mm screws.

Step 8 – Checking the Installation

When power is applied to the Zip Display, the version number is displayed in the top left of the LCD.

As soon as the ZipMaster is communicating with the Module a menu will be displayed. Press the left button (Info) to illuminate the backlight, and again to display version and address information.

Technical Support

If you require further help on installing Zip please contact our support team on +44 (0)1273 694422 or visit www.northbt.com/support.

Warranty

North warrants goods of its manufacture as being free of defective materials and faulty workmanship for one year from the date of purchase. If this product should become defective please contact our support team. This warranty becomes invalid if the product has been tampered with or used in an environment which is unsuitable.

EMC Conformance

The design and manufacture of North products conforms to the appropriate Electromagnetic Compatibility (EMC) standards, but correct installation is required to ensure that performance is not compromised.



WEEE Directive

The Waste Electrical and Electronic Equipment (WEEE) Directive requires the recycling of waste electrical and electronic equipment. Whilst the directive does not apply to some of North's products, we support its requirements as part of our environmental policy and we ask you to be aware of how you should dispose of this product. The crossed out wheelie bin symbol found on our products signifies that it should not be disposed of in general waste or landfill.



Please contact North or visit www.northbt.com/weee for more information on product disposal.