

Product Engineering Guide

ZIP Module 7202A

Introduction

With the decrease of large programmable controllers and the increase of 'fixed function' controllers being used in buildings there is a growing need for a cost effective way of picking up extra inputs and outputs. ZIP is a modular data acquisition system. It is designed to operate either within a control panel or stand-alone.

A 'ZIP System' is a collective term for the connection of ZIP Modules, ZIPNet, and a ZIPMaster. Some ZIP Modules link together in a 'daisy chain' style using PowerZIP connectors, while others have power and ZIPNet connections built in. A module with built in power and ZIPNet connections is the M7202A.

ZIP M7202A

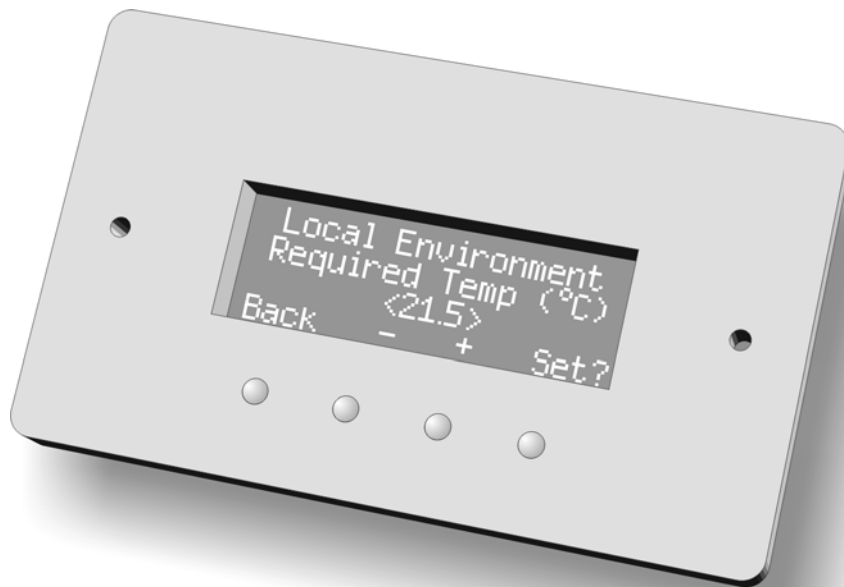

(147mm x 87mm)

The ZIP M7202A is North Building Technologies' "4 line" LCD user interface module. The module has been sized to fit into a standard 2-gang back box. It is designed to flush mounted on the front of a panel for use by engineers, or wall mounted for end users to obtain information and control connected building systems.

The display and buttons on the ZIP M7202A can set up to show pages from User Data (Auto mode) or can be defined by the engineer (Manual mode).

The M7202A also has a thermistor input and the ability to accept standard North alarms.

Engineering

Step 1 – Power down ZIP System

Before connecting the ZIP M7202A to the ZIPNet, turn off the power to the Zip System.

Step 2 – Set the ZIP Module's Address

Set the ZIP Module's unique address using the Address Switch. The address of a module must be in the range of 0-15.

Step 3 – Connecting the 12V power supply

Connect a 12VDC @ 200mA power supply to the terminals marked 'Power' on the ZIP M7202A. See section '**Power Supply and Network**'

Step 4 – Connecting the ZIP Net

Using RS485 cable connect the ZIP M7202A to your ZIPMaster. See section '**Power Supply and Network**'

Step 5 – Connecting the Thermistor

If required connect a 10K3A thermistor to the ZIP M7202A terminals marked Thermistor.

Step 6 – Power up ZIP System, including the M7202A

When power is applied, the display temporarily will show a version number in the top left hand corner without the backlight being illuminated. (Note the contrast will need to be adjusted to see the version number)

Step 7 – Object Engineering

Use object-engineering software to access your ZIPMaster and set up the objects within the M7202A.

For greater detail see the relative sections in '**M7202A Objects**'.

Data from your ZIP Module can now be accessed to test that it is functioning correctly.

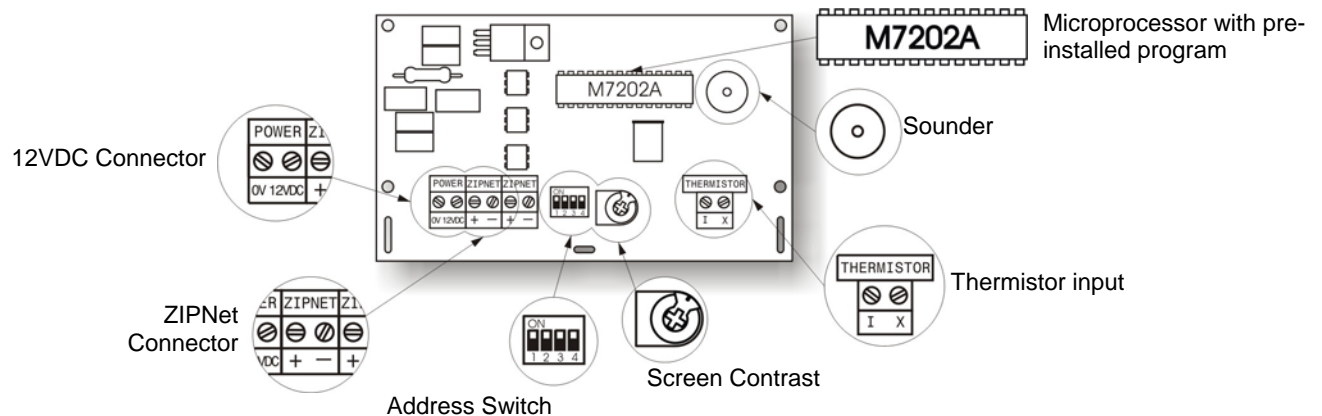

Address Switch

The Address Switch allows the module address to be set. There are 16 different addresses available; set with different combinations of the 4 switches labelled 1 to 4. Up is on and down is off.

Module Address	Switch Position			
	1	2	3	4
0	Off	Off	Off	Off
1	On	Off	Off	Off
2	Off	On	Off	Off
3	On	On	Off	Off
4	Off	Off	On	Off
5	On	Off	On	Off
6	Off	On	On	Off
7	On	On	On	Off

Module Address	Switch Position			
	1	2	3	4
8	Off	Off	Off	On
9	On	Off	Off	On
10	Off	On	Off	On
11	On	On	Off	On
12	Off	Off	On	On
13	On	Off	On	On
14	Off	On	On	On
15	On	On	On	On

Examples



With the Address Switch set with 1=on, 2=off, 3=on, 4=off, the modules address will be 5.



With the Address Switch set with 1=on, 2=off, 3=off, 4=on, the modules address will be 9.

Power Supply and Network

The ZIP M7202A requires a minimum power supply of 12VDC @ 200mA (the power connections are polarity dependent). The same 12V-power supply can also be linked to further ZIP M7202A or ZIP NetCards (NC12A or NC12B), on the ZIPNet. The ZIPNet is a bi-directional bus, based on the RS485 communications standard. This allows a total bus length of 1000m.

Connect suitable cable to the ZIPNet terminals marked '+' and '-' from the pervious ZiP device, and connect them to the '+' and '-' on the M7202A (connections are polarity dependent).

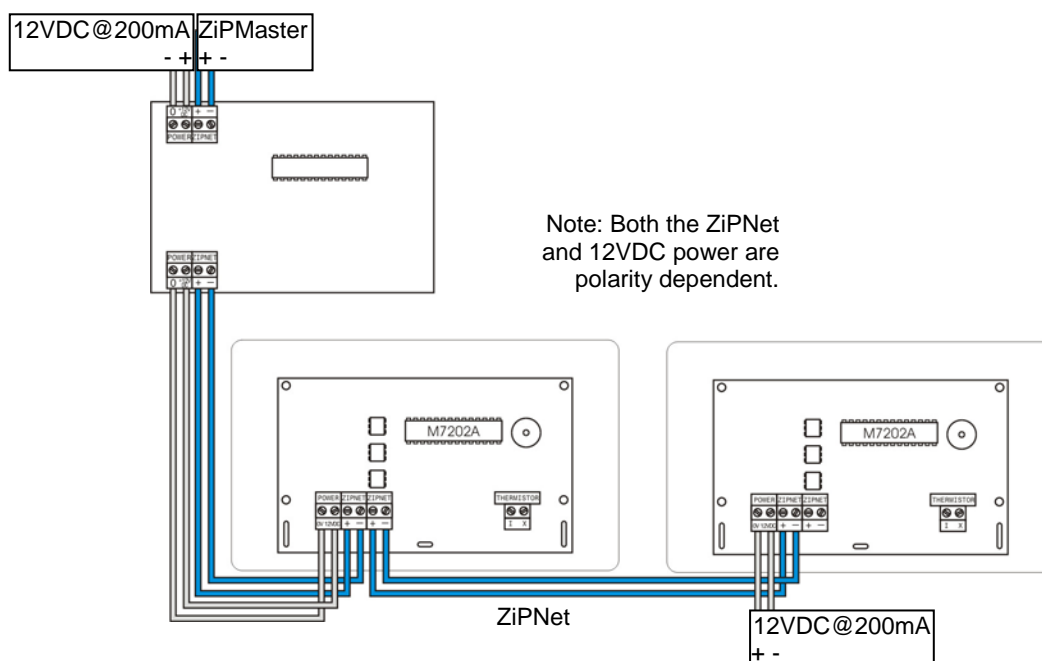

M7202A Objects

When the M7202A has the correct 12VDC power and has been connected to the ZIP System, access your ZIP Master using Object Engineering software and set up the objects within the module. As mentioned earlier the M7202A can be engineered to show pages from User Data (Auto mode) or, the text and the function of the buttons can be defined by the engineer (Manual mode).

Operation in Auto Mode

Auto Mode is designed to operate in conjunction with a User Data system, which should be engineered before setting up the M7202A. With a User Data system engineered and the M7202A connected to a ZIP Master and powered on use Object engineering software access the 'keyboard' object in the M7202A. Set the 'Operating Mode' to 'Auto' and specify the location of the User Data in the 'Destination Object.' The 'State' should read back 110, this means the M7021A has finished requesting information from the User Data and is ready for use.

Press any button on the M7202A once to 'wake the module up', and the backlight will illuminate (if no action is taken for 40 seconds the backlight will turn itself off and the module will need to be woken up again). The module will display the User Data's Label and the name of the first Page. By pressing button below the text 'Next' the pages set up in User Data can be scrolled through, once passed the first page a 'Prev' will appear to allow you to view the previous page. Holding a button down will cause the display to scroll continuously. Once the desired page has been found then press the 'Open' button to access the information on that page.

Once again use 'Next' and 'Prev' scroll through the values. If a value is adjustable the text 'Set' will appear. Pressing the 'Set' button will change the 'Prev and Next' buttons to '- +' . By using '- +' the value can be adjusted. To confirm the change press set, the new value is then written in to User Data and subsequently on to the device being controlled, to reject the change press the 'Back' button.

To return to the list of pages press the 'Back' button. If no action is taken for 40 seconds the backlight will turn itself off and the module will need to be woken up again.

Alarms

The M7202A is capable of delivering an alarm to a user. It does this by audible warning attracting the user to the display. The user can then view the alarm by 'wake the module up' and pressing the 'Info' button located on the root page. The user then choose to 'Clear' the alarm which will silence the audible warning, or may press the 'Back' button which will leave the audible warning running and the alarm in place.

Operation in Manual Mode

Manual Mode allows the engineer to define the text and the function of the four buttons. To use the M7202A in Manual Mode an OBV Process needs to be running for the module to pass values to. Use Object engineering software access the 'keyboard' object in the M7202A. Set the 'Operating Mode' to 'Manual' and specify the location of an input into an OBV Process in the 'Destination Object'.

Each time a button is pressed a value will be written to the 'Destination Object'. From left to right the buttons have a value of 1, 2, 3, and 4. If the third and fourth buttons are pressed together then a value of 5 is sent to the 'Destination Object'.

The four text lines (20 Characters each) and the backlight are controlled by writing values to them. When writing a new line of text it should contain 20 characters including spaces.

The alarm reporting feature of the M7202A does not operate when the module is in Manual mode.

PIN

The M7202 can be lock to prevent adjustments by non authorised users. In the 'keyboard' section of engineering a PIN can be configured using the digits 1, 2 and 3 i.e. "2312". The Pin can have a minimum of one digit and a maximum of eight. When a PIN is in use the 'Info' button on the display is changed for 'PIN' which links to an area for logging on.

The display will remain logged on until the user re-enters the PIN area and enters a blank PIN.